

V.1

OPTIMO

OP2 24 UNI

GB ELECTROMECHANICAL LINEAR OPERATOR FOR LEAF GATE



GB INSTRUCTIONS AND WARNING FOR INSTALLATION, USE & MAINTENANCE



- I** DESCRIZIONE PARTICOLARI OP2
- GB** SPECIFIC DESCRIPTION OP2
- F** DESCRIPTION SPECIFIQUE OP2
- E** DESCRIPCIONES PARTICULARES OP 2
- P** DESCRIÇÕES PRELIMINARES OP2
- D** BESCHREIBUNG DER OP2

6 5RI17500	<div style="display: flex; justify-content: space-between;"> <div style="width: 30%;"> <p>28 29 30 31 32 33</p> </div> <div style="width: 60%; text-align: center;"> </div> </div> <p style="text-align: right; font-size: small;">OP20027</p>
---------------------------------	--

1 5RI17000	<div style="display: flex; justify-content: space-between;"> <div style="width: 30%;"> <p>1 2 3 4 5 6</p> </div> <div style="width: 60%; text-align: center;"> </div> </div> <p style="text-align: right; font-size: small;">OP20022</p>
---------------------------------	--

7 5RI17600	<div style="display: flex; justify-content: space-between;"> <div style="width: 30%;"> <p>34 35 36 37 38 39 40 41</p> </div> <div style="width: 60%; text-align: center;"> </div> </div> <p style="text-align: right; font-size: small;">OP20028</p>
---------------------------------	--

2 5RI17100	<div style="display: flex; justify-content: space-between;"> <div style="width: 30%;"> <p>7 8 9 10 11</p> </div> <div style="width: 60%; text-align: center;"> </div> </div> <p style="text-align: right; font-size: small;">OP20023</p>
---------------------------------	--

8 5RI17700	<div style="display: flex; justify-content: space-between;"> <div style="width: 30%;"> <p>42 43 44 45</p> </div> <div style="width: 60%; text-align: center;"> </div> </div> <p style="text-align: right; font-size: small;">OP20029</p>
---------------------------------	--

3 5RI17200	<div style="display: flex; justify-content: space-between;"> <div style="width: 30%;"> <p>12 13 14 15</p> </div> <div style="width: 60%; text-align: center;"> </div> </div> <p style="text-align: right; font-size: small;">OP20024</p>
---------------------------------	--

9 5RI17800	<div style="display: flex; justify-content: space-between;"> <div style="width: 30%;"> <p>46 47 48 49 50</p> </div> <div style="width: 60%; text-align: center;"> </div> </div> <p style="text-align: right; font-size: small;">OP20030</p>
---------------------------------	---

4 5RI17300	<div style="display: flex; justify-content: space-between;"> <div style="width: 30%;"> <p>16 17 18 19 20</p> </div> <div style="width: 60%; text-align: center;"> </div> </div> <p style="text-align: right; font-size: small;">OP20025</p>
---------------------------------	---

10 5RI17900	<div style="display: flex; justify-content: space-between;"> <div style="width: 30%;"> <p>51 52 53</p> </div> <div style="width: 60%; text-align: center;"> </div> </div> <p style="text-align: right; font-size: small;">OP20031</p>
----------------------------------	---

5 5RI17400	<div style="display: flex; justify-content: space-between;"> <div style="width: 30%;"> <p>21 22 23 24 25 26 27</p> </div> <div style="width: 60%; text-align: center;"> </div> </div> <p style="text-align: right; font-size: small;">OP20026</p>
---------------------------------	---

11 5RI18000	<div style="display: flex; justify-content: space-between;"> <div style="width: 30%;"> <p>54 55 56 57</p> </div> <div style="width: 60%; text-align: center;"> </div> </div> <p style="text-align: right; font-size: small;">OP20032</p>
----------------------------------	--



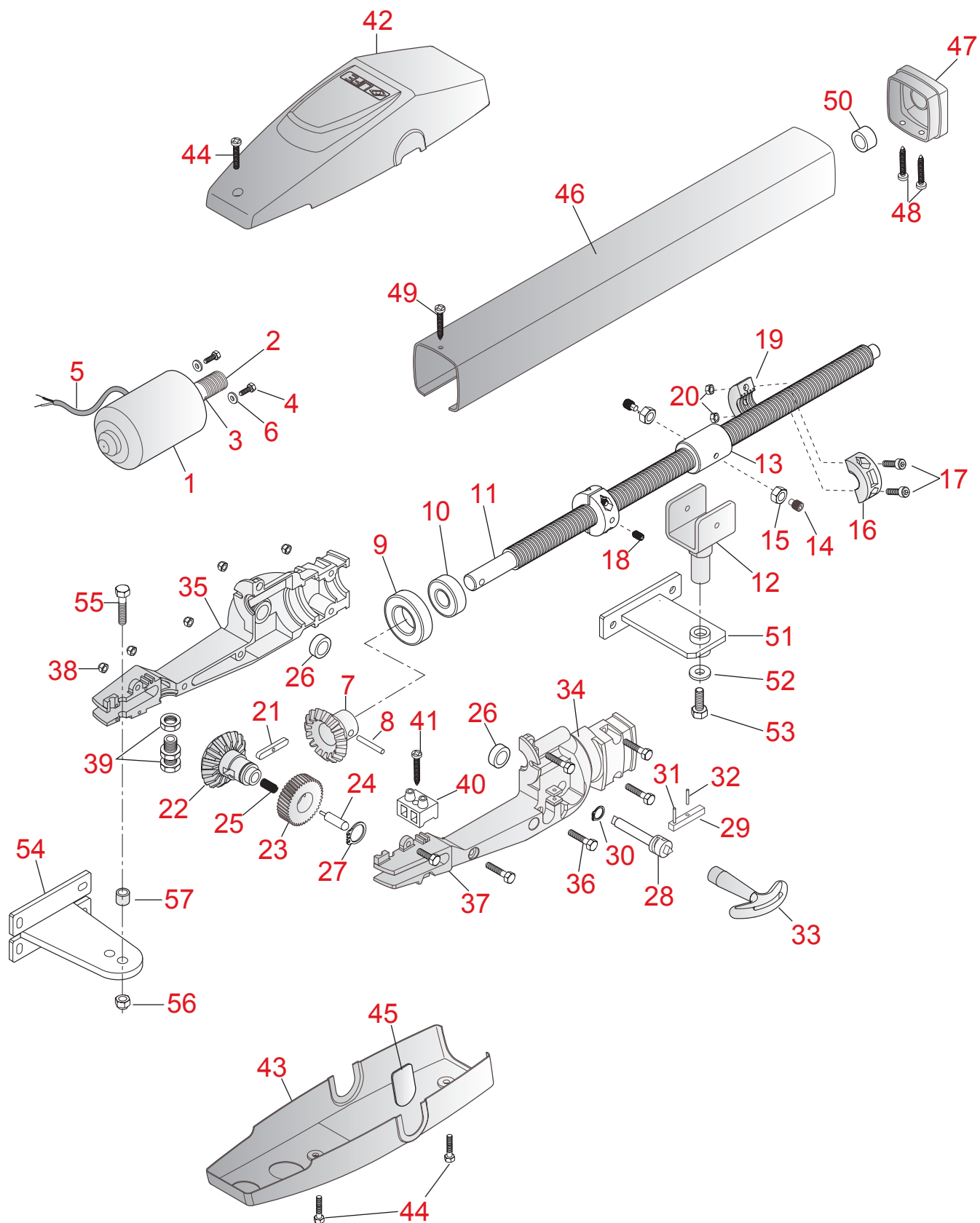

OP20021

TECHNICAL DATA

OP2		OP224 UNI	OP224 INI
Irreversible mechanical 24V operator for swinging gates, with mechanical stops			
Main power supply	V	230 Vac 50 Hz	
LIFE electronic unit power supply	V	24 Vdc	
LIFE electronic board: GE UNI 24R		Yes (1 motor)	Yes (2 motors)
max power	W	40	40+40
max input	A	3	3+3
Input current to line (230V)		1,1	1,5
Push	N	1500	
Lubrication	Type	Permanent grease	
Limit switches		2 (mechanical)	
Reduction ratio		1/672	
Max. rod run	Mm	350	
Operating temperature	°C	da -20 a +70	
Protection level	IP	44	
90° opening time	S	18	
Intermittence	%	80	
Nominal time work	min.	20	
Motor isolation class		D	
Battery recharge time*	h	48	
Operator weight	kg	3,7	
Dimensions	mm	90x755x110	
Use in acid, salt or potential explosive atmosphere		no	
Max. leaf span & weight		2 m - 200 kg	

* for 2 Ah battery (optional & installed within the control board).



INSTALLATION

Use limits

The type and height of the gate, the shape of the leaves and weather conditions are the use limits; they have to be taken into consideration during installation. Figures shown on table 3 are approximative.

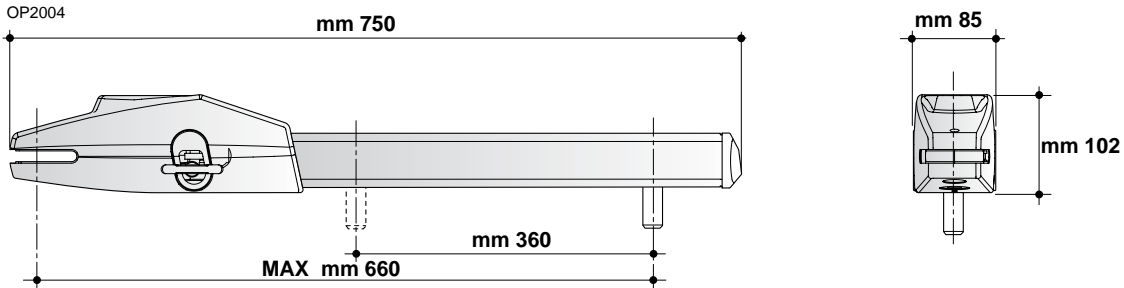

Tab. 2: use limits model OP2

Max leaf span (m)	Max leaf weight (Kg)
1,50	300
2,00	200

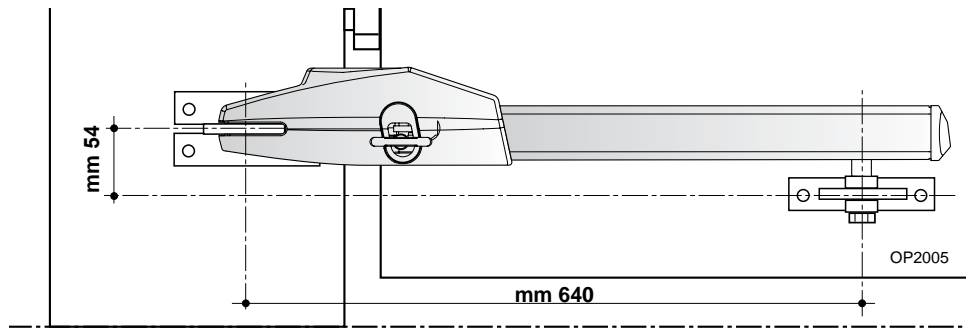

Standard Installation

A) TWO-LEAF SYSTEM

The definition of leaf 1 and leaf 2 of the gate is essential for automation operation.

Leaf 1: is the first to open (1) when the gate is closed and the second to move when the gate is open; it finishes its closure travel after leaf 2.

Leaf 2: is the second to open (2) when the gate is closed and the first to move when the leaves are open; it finishes its closure travel before leaf 1.

B) ONE-LEAF SYSTEM

Leaf 1: the gate's only leaf.

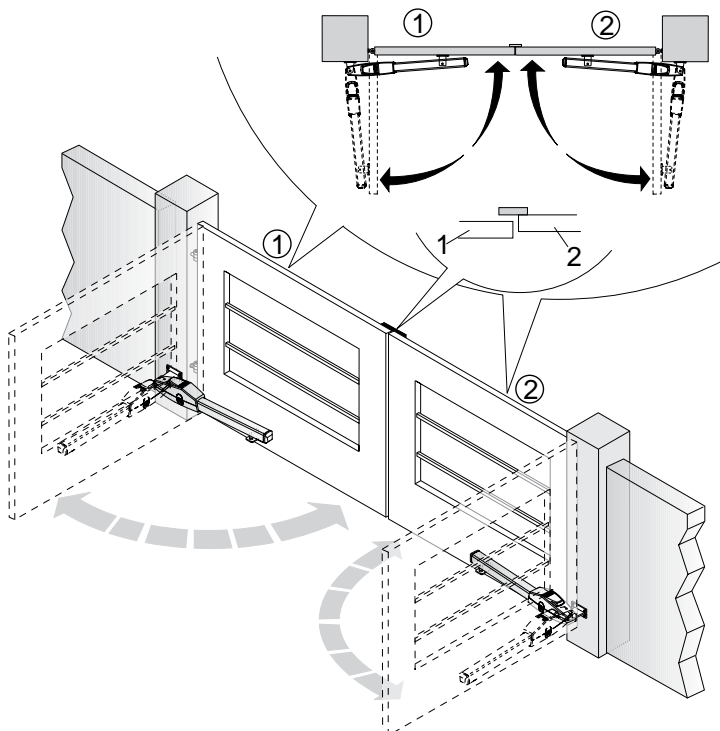

2) ONE LEAF SYSTEM

Leaf 1: only leaf of the gate..

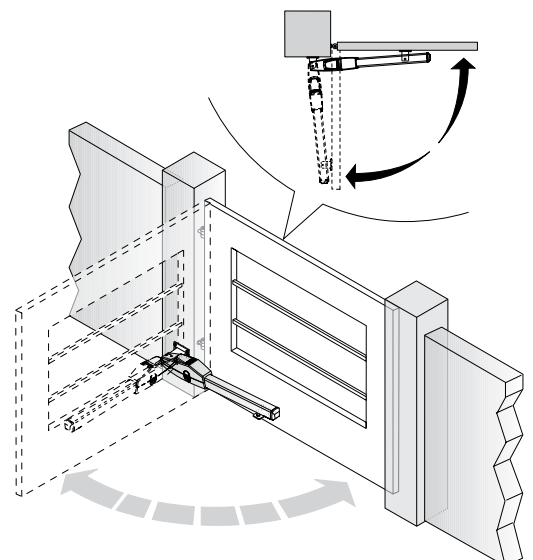

Check that the distance "C" on the gate support structure is no greater than the value given in the table below. If the distance is higher than this value, it is necessary to intervene by making a niche in the structure to obtain the indicated value. This is to avoid the linear operator colliding with the edge of the structure during closure. The niche must be made in the area in which the linear operator is to be installed and it must have a height such as to allow operator passage.

fig. OP2005 shows the set up measurements for the operator installation:

Table.3 shows A and B values recommended for a 90° leaf opening (angle α)

Table. 3: operator installation measurements

Opening	A mm	B mm	C max mm	D mm
90°	160	160	70	630

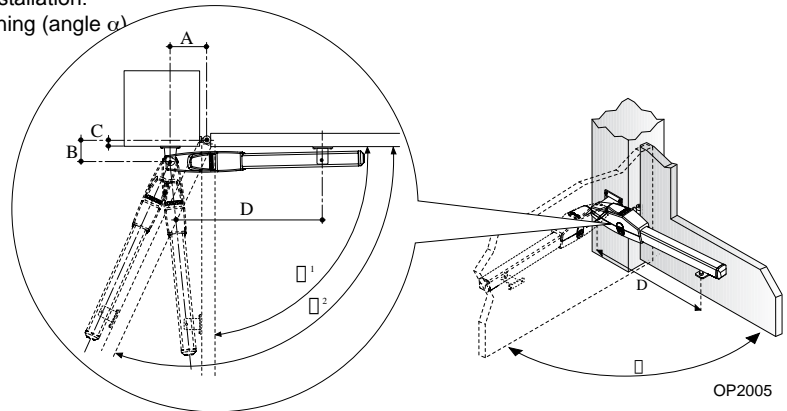

We recommend not to chose A & B values too different one another, in order to garantee a regular leaf movement and a minimum stress on the operator;

Measurement A: if increased, the opening angle increases too, and so force on the leaf decreases, and opening/closing speed increases.

Measurement B: if increased, the opening angle decreases, and so force on the leaf increases, and opening/closing speed decreases.

Rear bracket position

- Define the position of the rear bracket , See table 3 above for A, B & C measurements
- Check the exit of the electric wires tube position to be under the bracket (3).
- Check sufficient space for the fixing (screws or welding) of the front bracket to the leaf.
- Check the rear bracket is horizontal before fixing
- Fix (with screws or welding) to the pillar in the desired position.

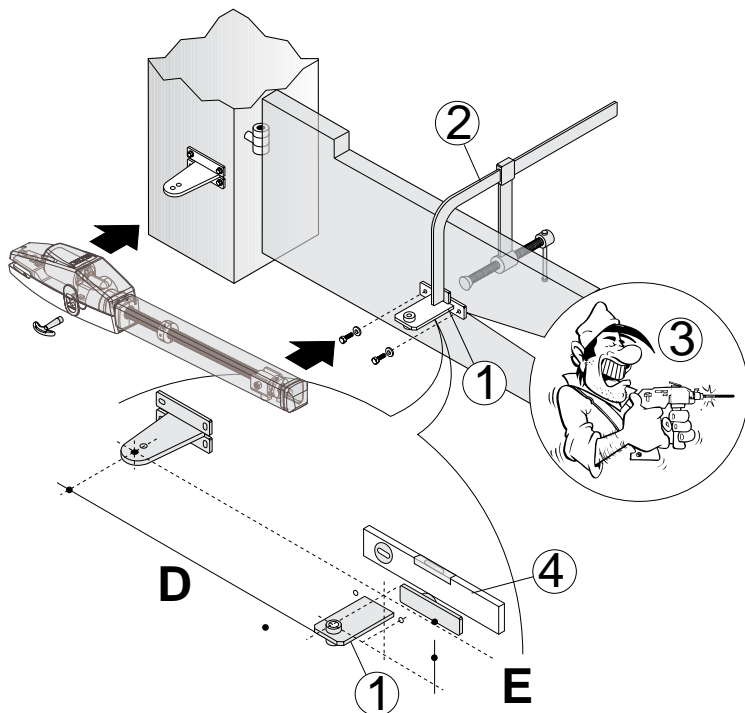
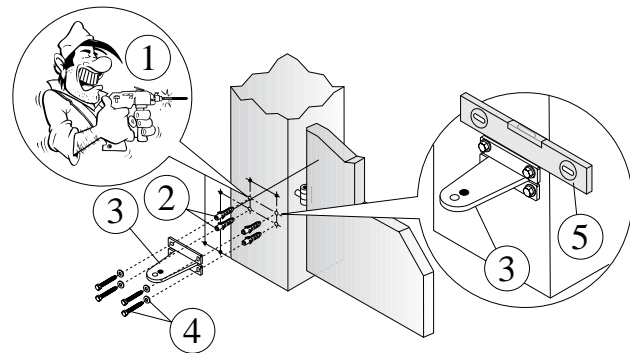

Front bracket position

- Take the leaves to the closed position against the mechanical stop
- Bring the front bracket (1) to distance D (630mm) from the rear bracket
- Position the front bracket (1) 54mm lower than the rear bracket (distance E)
- Temporarily clamp the front bracket (1) to the gate in the correct position
- Check the bracket is horizontal before fixing in place (4)

Distance D 630mm
Distance E 54mm

Operator position and stop adjustment

1. To unlock operator, insert key (1) and turn 360° anti-clockwise. From now on, the operator is unlocked, see fig. OP2009.

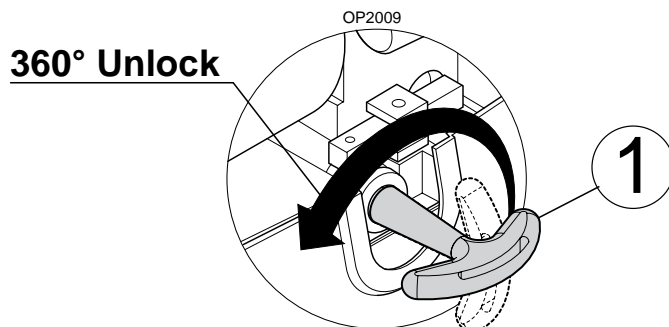

2. Take the motor cover off (3) by removing screw (1). Remove the motor cover taking care not to damage the retaining clips. Remove screw (4) and slide cover from worm screw (5).

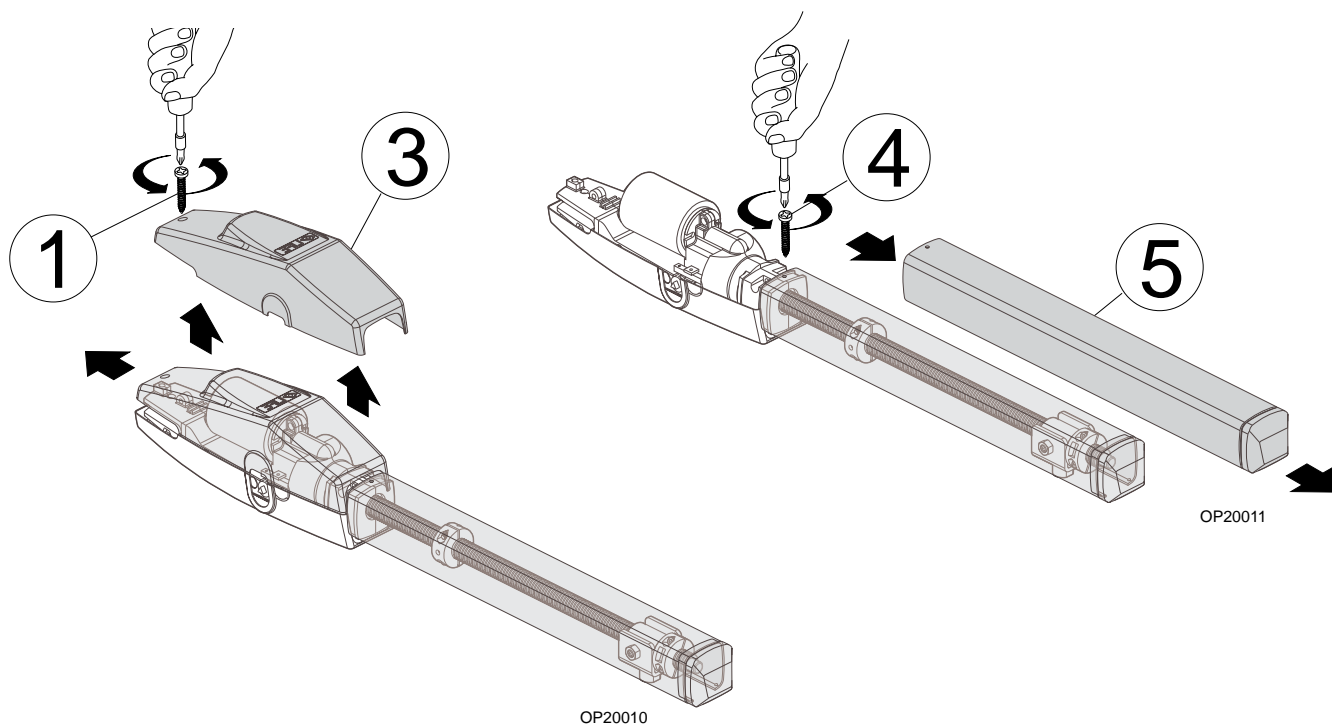

3. Lift the operator and insert the drive pin (1) in the hole of the front bracket (2), see below

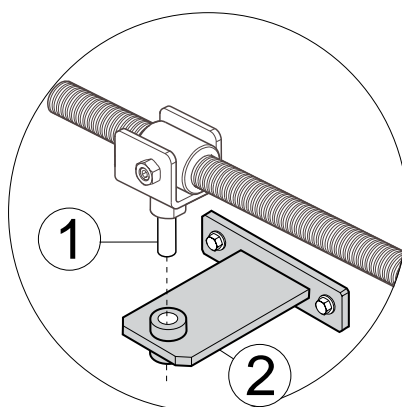

4. Place the ferrule insert(5) in to the hole of rear bracket(3) slide the operator arm(6) on to the bracket(3), aligning the hole with ferrule insert. Position the bolt(7) and push through the operator arm and rear bracket hole. Secure with the self locking nut(8)

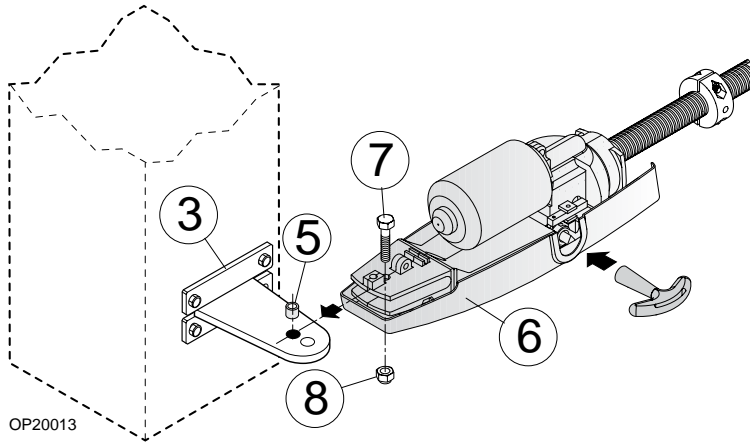

5. Fix operator (6) on front bracket (3) with screws closing strongly.
6. Open and close manually the gate several times, and check gate movement is regular, and operator movement is parallele to the gate movement.
7. Check ferrule support perfectly slides on operator's screw nut, and that with gate opened and closed, at least 5 mm remain between ferrule screw nut and opening & closing stops.
8. If necessary, use different hole on rear bracket, repeating operations shown on point c) & d).
9. Define accurately opening and closing positions of gate leaves, adjusting the stop positions in the following way:
 - § bring gate in closing position on mechanical stop,
 - § loosen closing stop(1) with allen key and move it up until it touches the drive pin bracket(5); then re-tighten the screws firmly and insert the headless locking screw(6). Tighten the headless screw(6).
 - § bring gate leaf in to the required open position
 - § loosen the opening stop(2) with an allen key and move it up until it touches the drive pin bracket(5); then re-tighten the screws firmly and insert the headless screws(7). Tighten the headless screw.

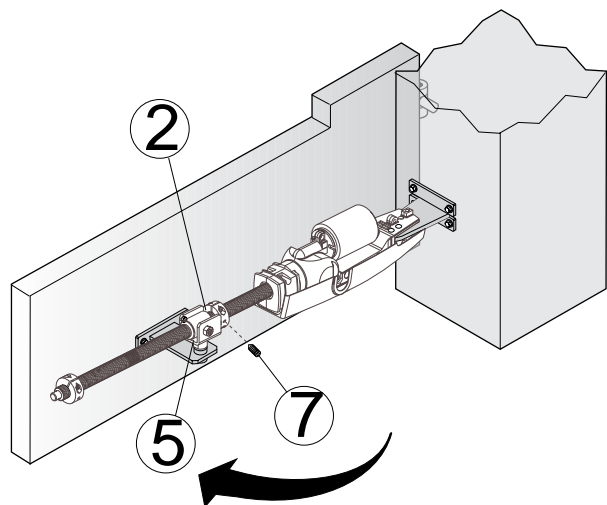
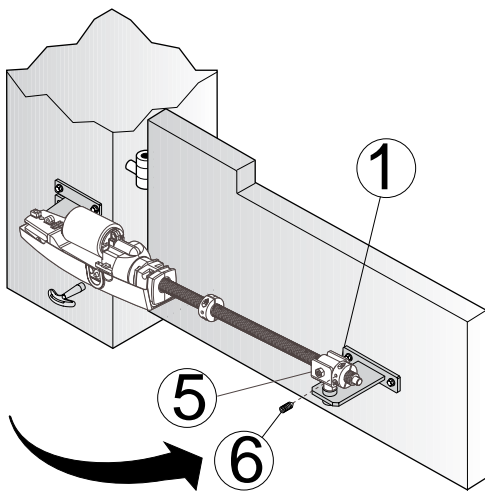

10. Re-lock the operator with the manual release key by turning 360 degrees clockwise.
12. Re-fit the worm screw cover, then the motor cover.

Operator unlocking

ATTENTION:

- **Installer must fix the unlocking operation label to the manual unlocking key.**
- **Manual unlocking activation could cause a uncontrolled gate movement, due to mechanical damages, or mechanical unbalanced conditions.**
- **Prior to maneuver, cut power to automation.**
- **Avoid pressure on key, or it will brake.**

This command will allow operator's transmission release, and manual leaf movement; it can be used in case of power failure or installation malfunction.

The unlocking occurs through a key that must be kept in a safe place.

- a) Lift lock lid protection (1)
- b) Insert triangle key (2) in lock and turn 360° anticlockwise ; gate transmission is now released.(4).

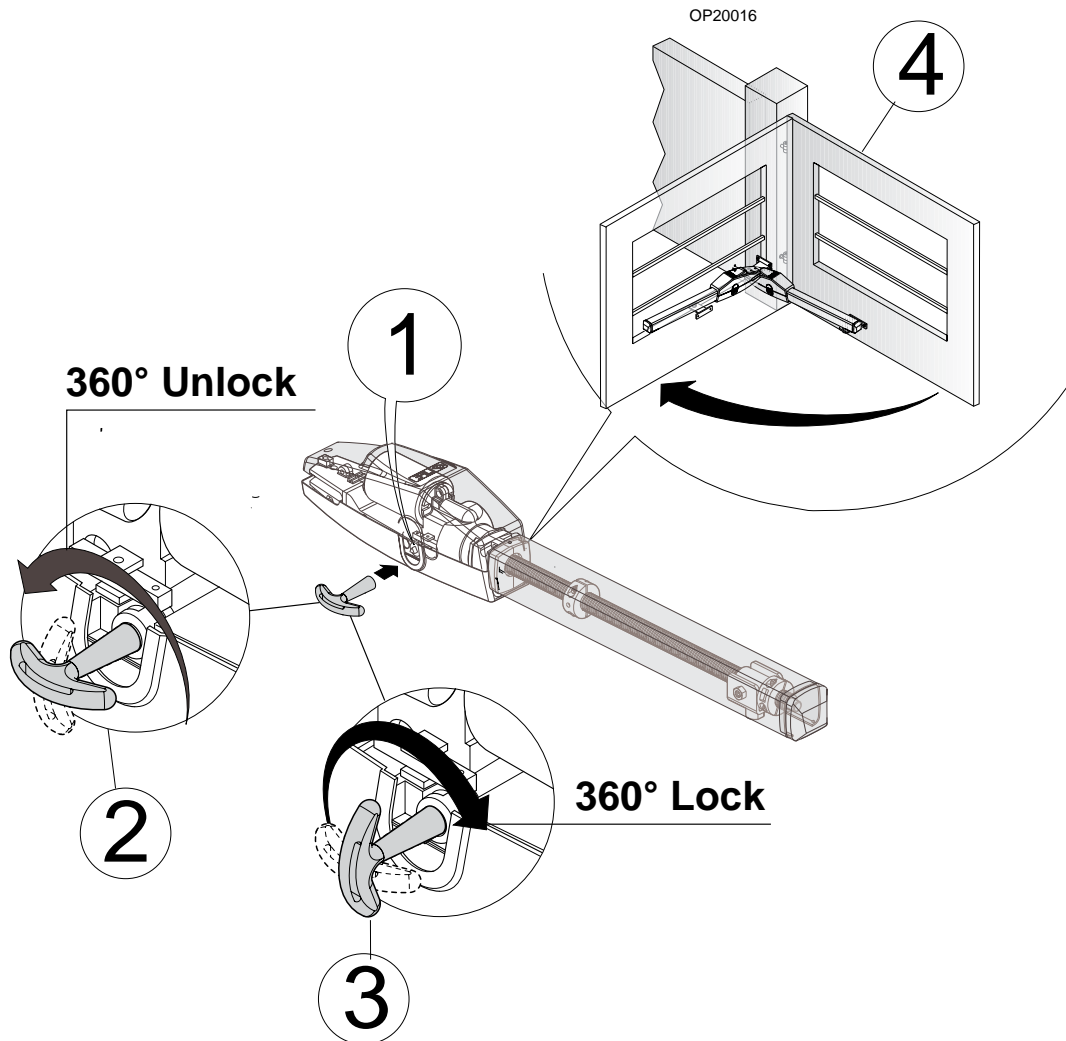

- c) Leaf is now free and can be manually operated.
- d) To relock leaf, insert triangle key (3) and turn 360° clockwise; transmission is blocked again

LINKAGES AND CONNECTIONS

Before proceeding with connections, please read carefully sections regarding **SAFETY**.

All linkage & connection operations must be carried out with the control board disconnected from power supply; if disconnection device cannot be seen, apply a poster: "WARNING: MAINTENANCE IN PROGRESS".

Internal operator wiring operated by factory must not be alienated.

Operator electric connection

To enter inside wiring, remove cover (1) unscrewing screws (2), see fig. A

Tab. 5: electric wires description

Pos.	Connection	Wire type
1	Motor supply	Wire 2x1,5 mm ²

Fix 2 power wires (5) 2x1,5 mm² to plug (4). Remember red colored wire is **+** and blue colored wire is **-**.

Clamp wire block (6) slightly loosening the wire from plug.

Fig. A

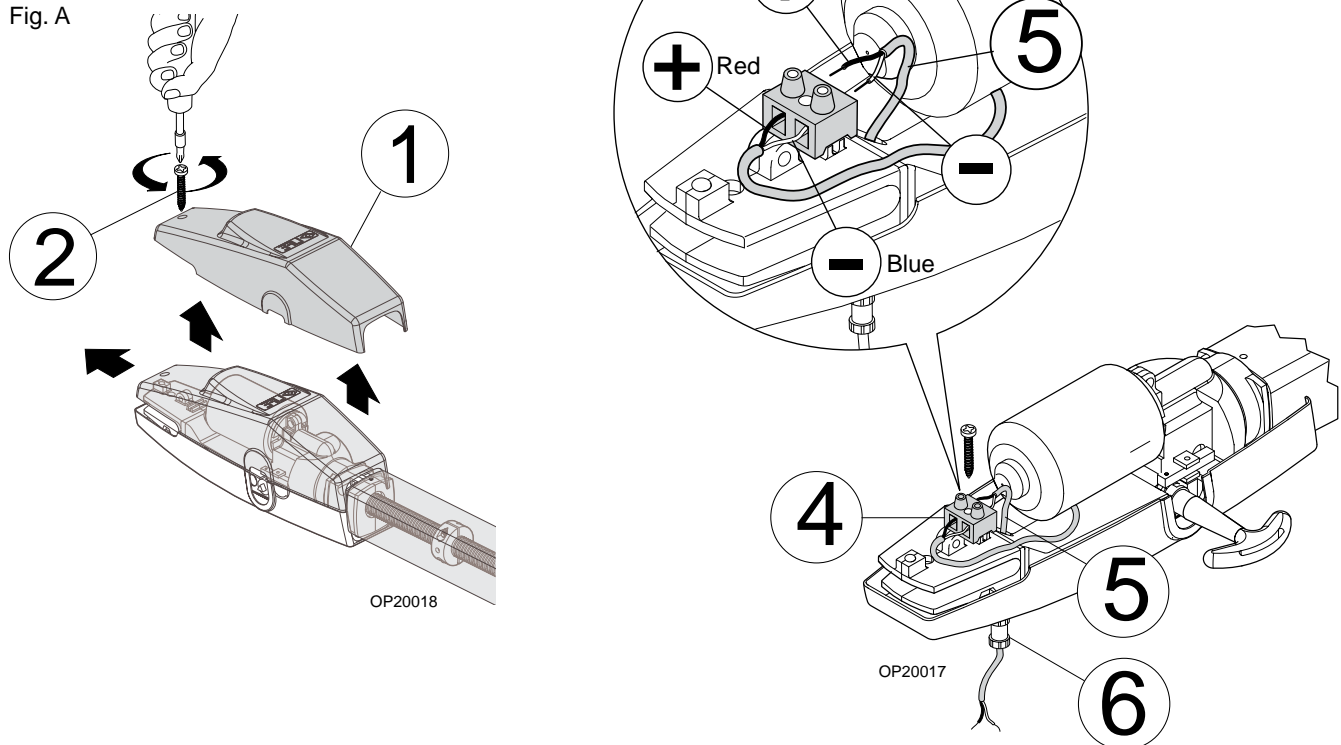



GENERAL INFORMATION

It is strictly forbidden to copy or reproduce this instruction manual without written permission to do so and subsequent verification by LIFE home integration. Translation into other languages of all or part of the manual is strictly forbidden without previous written authorisation from and subsequent verification by LIFE home integration. All rights on this document are reserved.

LIFE home integration will not accept responsibility for damage or malfunctions caused by incorrect installation or improper use of products and Users are therefore recommended to read this manual carefully.

LIFE home integration will not accept responsibility for damage or malfunctions caused by the use of the automation together with the devices of other manufacturers; such action will render the warranty void.

LIFE home integration will not accept responsibility for damage or injury caused by non-compliance with the installation, set up, maintenance and use indications contained in this manual and the safety instructions described in the SAFETY INSTRUCTIONS AND WARNINGS chapter.

With the aim of improving its products, LIFE home integration reserves the right to bring about alterations to them at any time, without giving prior notice. This document conforms to the state of the automation at which it is provided when released for sale.

INFORMATION ON THE MANUFACTURER

LIFE home integration is the manufacturer of the OPTIMO automation (and will hereinafter be referred to as manufacturer) and the owner of all rights concerning this document. The Manufacturer's information required by Machinery Directive 98/37/EC is as follows:

§	Manufacturer:	LIFE home integration S.r.l.
§	Address:	Via I Maggio, 37 – 31043 FONTANELLE (TV) Italy
§	Telephone:	+ 39 0422 809 254
§	Fax:	+ 39 0422 809 250
§	http:	www.homelife.it
§	e-mail:	info@homelife.it

The identity plate bears information on the Manufacturer of the operator and specifies the type and date (month/year) of manufacture. For further information on technical or commercial issues and technician call-out and spares requests, Clients may contact the Manufacturer or area representative from whom the product was purchased.

INTENDE USE

- § **OPTIMO is a low voltage, irreversible, articulated, mechanical operator designed exclusively for opening and closing one- and two-leaf residential type swing gates only. Improper use or use on gates larger than those indicated in the TECHNICAL DATA and USAGE RESTRICTIONS chapters will be considered non-conform to the intended use. The Manufacturer declines all responsibility for other use. The owner accepts full responsibility for improper use, which will result in the warranty being rendered void.**
- § **Any usage differing from that described above is forbidden.**
- § **The operator may not be installed or used in potentially explosive environments.**
- § Motorised gates must conform to current European standards and Directives, including EN 12604 and EN 12605.
- § The operator may only be used when in perfect working order and in compliance with the intended use, in the awareness of safety and hazard conditions and in compliance with the instructions for installation and use.
- § Any dysfunctions that may pose threats to safety must be eliminated immediately.
- § The gate must be stable, properly hung and resistant to flexion (it must not bend during opening and closure movements).
- § The operator cannot compensate for faulty or incorrectly hung gates. The operator may not be used in environments prone to flooding.
- § Do not use the operator in environmental conditions characterised by harsh atmospheric agents (e.g. salty air).

1 SAFETY INSTRUCTIONS AND WARNINGS

GENERAL INSTRUCTIONS AND WARNINGS

- § **The Manufacturer declines responsibility for damage or injury caused by non-conformity with the information supplied concerning installation, trial run, use and maintenance contained in this manual, and the failure to observe the safety instructions given below.**
- § **The installation, connection, testing, trial run and maintenance of the operator must be performed by a COMPETENT PERSON aided and supervised by a PROFESSIONAL FITTER.**
- § **Given the technical, procedural, regulation and legal implications of the work, unauthorised fitters are not permitted. Installation requires a practical and theoretical knowledge of mechanics, electronics and electrics, and of sector laws and standards.**
- § **Amateur installation IS STRICTLY FORBIDDEN as it does not comply with current standards and laws and therefore does not guarantee the safe operation of the automation.**
- § **Do not proceed with installation, connection and trial run in the event of doubts or indecision of any kind.**
- § **This manual must be read carefully and understood before installing the operator. If doubts arise during installation, contact a PROFESSIONAL FITTER or the MANUFACTURER.**
- § **Only mount the operator on gates that are perfectly hinged and well balanced. A gate that is not correctly hinged and balanced can cause serious injury to the user and/or damage to the operator.**
- § The Manufacturer declines all responsibility for damage and faults to the operator caused by non-observance of the instructions contained in this manual.
- § Keep this manual in a safe and easily accessible place so that it can be consulted rapidly when necessary.
- § During installation, connection, trial run and usage of the operator, observe all applicable accident prevention and safety regulations.
- § In the interests of safety and optimal functioning of the operator, only use original spares, accessories, devices and fastening apparatus.
- § Do not perform alterations to any operator device or component. This type of operation may cause malfunctions. The Manufacturer declines all responsibility for damage caused by products that have been modified.
- § The operator should not be used until the setting up procedure described in the STARTING UP chapter has been performed.
- § Should liquids penetrate inside the operator, disconnect the electricity supply and contact the Manufacturer's Assistance Service immediately; use of the operator in such conditions may cause hazard situations.
- § In the case of faults or problems that cannot be resolved using the information contained in this manual, contact the Manufacturer's assistance service

STORAGE INSTRUCTIONS AND WARNINGS

The manufacturer declines all responsibility for damage and faults to OPTIMO operator functioning caused by non-compliance with the storage instructions.

- § **The operator must be stored in closed, dry places, at room temperatures of between -20 and +70°C.**
- § **Keep the operator away from sources of heat and naked flames, which could damage it and cause malfunctions, fires or hazard situations.**
- § **Keep the operator in a horizontal position, but not resting on the ground.**

SAFETY INSTRUCTIONS AND WARNINGS INDICATIONS AND WARNINGS FOR USE

- It is the fitter's duty to perform risk analysis and inform the user/owner of any existing residual risks. Any residual risk detected must be recorded in writing in the operator manual.
- Moving gates usually present the following residual risks: impact and crushing against the main closure surface of the leaf or between the leaves; impact and crushing in the opening area; shearing and dragging between the mobile and fixed guide and support parts during movement; mechanical risks caused by movement.
- The Manufacturer will not accept responsibility for damage or injury caused by the non-observance of the information on use contained in this manual, and the failure to observe the safety indications given below.
- The Manufacturer declines responsibility for damage and malfunctions caused by non-compliance with the instructions for use.
- Keep this manual in a safe, easily accessible place, so that it can be consulted rapidly when necessary. Before activating the gate ensure that all persons are at a safe distance.
- Never touch the gate or moving parts when in motion.
- Remain at a safe distance when the gate is in motion: only pass when the gate is completely open and immobile.
- Do not allow children to play with gate controls, do not leave radio control or other control devices within children's reach.
- Prevent children from playing or standing in the vicinity of the gate or the control organs (radio controls), the same precautions should be adopted for disabled persons and animals.
- In the event of malfunctions (noisiness, jerky movements, etc.) suspend the use of the automation immediately: failure to observe this rule may entail serious hazards, risks of accidents and/or serious damage to the gate and the automation. Contact a PROFESSIONAL FITTER and in the meantime use the gate manually by disconnecting the operator (see the OPERATOR/ACTUATOR RELEASE chapter).
- In order to maintain the automation in efficient conditions, ensure that the operations indicated in the MAINTENANCE chapter are performed at the frequency indicated by a PROFESSIONAL FITTER.
- Examine the installation frequently in order to ensure that there are no signs of mechanical unbalance, signs of wear and signs of damage to cables and assembled parts: do not use automations that require repair work or adjustments.
- Should liquids penetrate inside the operator, disconnect the power supply immediately and contact the Manufacturer's Assistance Service; the use of the automation in such conditions may cause hazard situations.
- If a problem arises that cannot be resolved using the information contained in this manual, contact the Manufacturer's assistance service.

INSTRUCTIONS AND WARNINGS FOR INSTALLATION

- Before commencing installation read the SAFETY INSTRUCTIONS AND WARNINGS chapter carefully.
- The COMPETENT PERSON who installs the operator is responsible for performing risk analysis and regulating the automation's safety devices consequentially.
- Before commencing installation, check whether further devices or materials are needed to complete the automation in order to suit the specific situation in which it will be used.
- The Fitter must check that the temperature range declared on the operator (see TECHNICAL DATA Chap.) is suited to the place in which the device is installed.
- The operator cannot be fitted on gates with separate pedestrian access, unless operator function is prevented when the gate is open.
- Before installing the operator, ensure that the gate is in good mechanical conditions, correctly balanced and that it opens and closes correctly.
- Ensure that the risk of entrapment between the open gate and surrounding parts following the opening movement is eliminated.
- Any normally open/off buttons installed for the activation of the operator must be positioned so that they are within view of the gate but distant from moving parts. Unless said devices operate using keys, buttons be positioned at a minimum height of 1.5m and not accessible to unauthorised persons.
- Once the automation has been installed, ensure that it is correctly adjusted and that the protection systems and release work properly.
- It is strictly forbidden to motorise a gate that is not already efficient and secure as the automation cannot resolve faults caused by incorrect installation or poor maintenance of the gate. During installation, make constant reference to harmonised standards EN 12453 and EN12445.
- Ensure that the individual devices to be installed are suitable for the automation that one intends to create, paying careful attention to the points raised in the TECHNICAL DATA chapter. Do not proceed if even just one device is unsuitable for the intended use.
- Ensure that the place of installation is not prone to flooding, does not contain sources of heat or naked flames, fires or hazard situations in general.
- During installation, protect automation components to prevent liquids (e.g. rain) and/or foreign bodies (earth, gravel, etc) penetrating inside.
- Wrapping materials must be disposed of in compliance with local regulations. Wear protective goggles when making holes for clamping.
- In the event of works at heights of over 2m from the ground, for example for the installation of the indicator lamp or aerial, fitters must be equipped with ladders, safety harnesses, protective helmet, and all other equipment required by law and the standards governing this kind of work. Refer to Directive 89/655/EEC amended by 2001/45/EC.

PRELIMINARY CHECKS

Before commencing installation, the following checks must be performed:

- 1) The weight and dimensions of the gate must not exceed the limits for use (see the TECHNICAL DATA and USAGE RESTRICTIONS chaps.), if they exceed such limits, the OPTIMO operator may not be installed.
- 2) The structure of the gate leaf must be suitable for the installation of the operator and conform to current standards. Provide all devices necessary to guarantee safe operation.
- 3) The gate leaves must be sturdy and solid; the hinges must be suited to the dimensions and weight of the leaves, gaps between parts must be minimal and they must be solidly fixed.
- 4) The gate's movement in both opening and closure must be uniform, without points of greater resistance to rotation or friction. Check manually by opening and closing the leaves several times.
- 5) The gate leaves must be well balanced, i.e. they must not move when left in any point during opening or closure. Ensure that the leaves not bend or deviate from their course during movement.
- 6) Gate leaf hinges must be perfectly vertical in order to avoid deviations during operation.
- 7) In two-leaf gates, when completely closed the two leaves must meet and match perfectly for their entire height, without forcing one against the other or remaining too distant, and they must be perfectly vertical.
- 8) Check the opening and closure mechanical end stops; they must be:
 - suited to the gate leaves and firmly fixed to the ground;
 - adequately robust;
 - free from potential damage to the gate leaves in the event of collision.
- 9) The operator installation area must not be prone to flooding and therefore it may not be installed too close to the ground.
- 10) The surfaces (column, pillar, wall, etc.) to which the operator's support bracket is fastened must be smooth and vertical, parallel to the leaf and sufficiently solid and compact to allow secure fixing.
- 11) Use fixing devices suited to the material of the surface (welding for metal tubes or screws and screw anchors for masonry).

MAINTENANCE

MAINTENANCE INSTRUCTIONS AND WARNINGS

- Once the automation has been tested, the parameters set must NOT be altered. If further adjustments (e.g. alterations to the force value) are made, ALL THE CHECKS REQUIRED FOR TESTING AND COMPLIANCE WITH STANDARDS MUST BE REPEATED.
- The Manufacturer declines responsibility for damage or injury caused by non-compliance with the information provided in this manual and the safety instructions provided below.
- The Manufacturer declines all responsibility for damage and malfunctions deriving from non-compliance with the maintenance instructions.
- In order to keep the operator efficient and safe, follow the cleaning, checking and routine maintenance procedures as described in this manual. This is the owner's duty.
- Any checking, maintenance or repair work must be conducted by a PROFESSIONAL FITTER
- Always switch off the electricity supply in the event of malfunctions, breakdowns and before any other operations in order to avoid the gate from being activated.
- Always disconnect the operator's power supply before performing any maintenance or cleaning operation.
- The owner is not authorised to remove the operator cover as it contains live parts.
- If the power cable is damaged, it must be replaced by the Manufacturer or its technical Assistance service or in any case a person with a similar qualification in order to avoid risks.
- Use original spare parts, accessories and clamping material only.
- Do not perform technical or programming modifications on the operator. Operations of this type may cause malfunctions and / or risk of accidents. The Manufacturer declines responsibility for damage deriving from modified products.
- In the event of intervention of automatic switches or fuses, before restoring function conditions identify and eliminate the fault. Request the intervention of a PROFESSIONAL FITTER.
- If a fault that cannot be solved following the information contained in the present manual arises, contact the manufacturer's assistance service.
- All maintenance, repair or replacement of parts must be recorded in the maintenance log, which is SUPPLIED AND INITIALLY FILLED IN BY THE FITTER.

CLEANING THE AUTOMATION

ATTENTION:

- § **Never wash the operator with jets of water or cleaning devices using water.**
- § **Do not use corrosive substances, solvents, thinners or spirits to clean the operator.**
- § **Before cleaning switch of the power supply**
 - a) Automations are almost always installed outdoors and are therefore subject to climatic changes and harsh weather conditions that transport debris that may cause problems.
 - b) The area in which the automation is installed must be kept clean to avoid malfunctions and faults.
 - c) Keep the gate area clean by using a broom to brush away stones, gravel, mud etc. that deposit there.
 - d) Keep the opening and closure stop plates clean

ROUTINE MAINTENANCE

Every 6 months a PROFESSIONAL FITTER should repeat the following operations:

- § A series of opening and closure tests using radio controls, internal button panels and selectors, making all the automation devices function (photocells, sensitive strips, flashing light, etc).
- § Check that the gate performs the desired action.
- § Grease the gate's bearings.
- § Repeat the series of tests described for automation testing

DEMOLITION AND DISPOSAL

- § The OPTIMO operator is constructed using various materials, which implies the adoption of different disposal procedures. Refer to regulations in force in the country in which the automation is installed.
- § Contact qualified firms for disposal.

ATTENTION: the automation may only be disconnected from the mains by a qualified electrician using suitable instruments.

MANUFACTURER'S DECLARATION OF CONFORMITY

Declaration of conformity



under Directive 98/37/EC, appendix II, part B (Manufacturer's Declaration of CE Conformity).

LIFE home integration
Via 1 Maggio, 37
31043 FONTANELLE (TV) – Italia
declares that the following product:

Swinging gate operator

OPTIMO 2

satisfies the essential requisites established in the following directives:

- § Machinery Directive 98/37/EC (formerly 89/392/EEC) and subsequent amendments,
- § Low voltage directive 73/23/EEC and subsequent amendments,
- § Electromagnetic compatibility directive 89/336/EEC and subsequent amendments.

and satisfies the following standards:

- § EN 12445:2000 Industrial, commercial and garage doors and gates – Safety in the usage of motorised doors – testing methods
- § EN 12453:2000 Industrial, commercial and garage doors and gates – Safety in the usage of motorised doors - Requisites.
- § EN 60204-1:1997 Machinery safety – Electric equipment of the machine – Part 1: general rules.
- § EN 60950 Information technology equipment - Safety - Part 1: General requisites
- § ETSI EN 301489-3:2001 Electromagnetic compatibility for radio equipment and appliances.
- § EN 300220-3:2000 Radio equipment and systems – short band devices – Technical characteristics and testing methods for radio apparatus with a frequency of 25 to 1000 MHz and powers of up to 500mW.

The Manufacturer also declares that it is not permitted for the abovementioned components to be used until such time as the system in which they are incorporated is declared conform to directive 98/37/EC.

Fontanelle 19.10.2004

Name:

Faustino Lucchetta

Position:

Amministratore Delegato

Signature

